

CHAMBERLAIN®

LiftMaster®

PROFESSIONAL

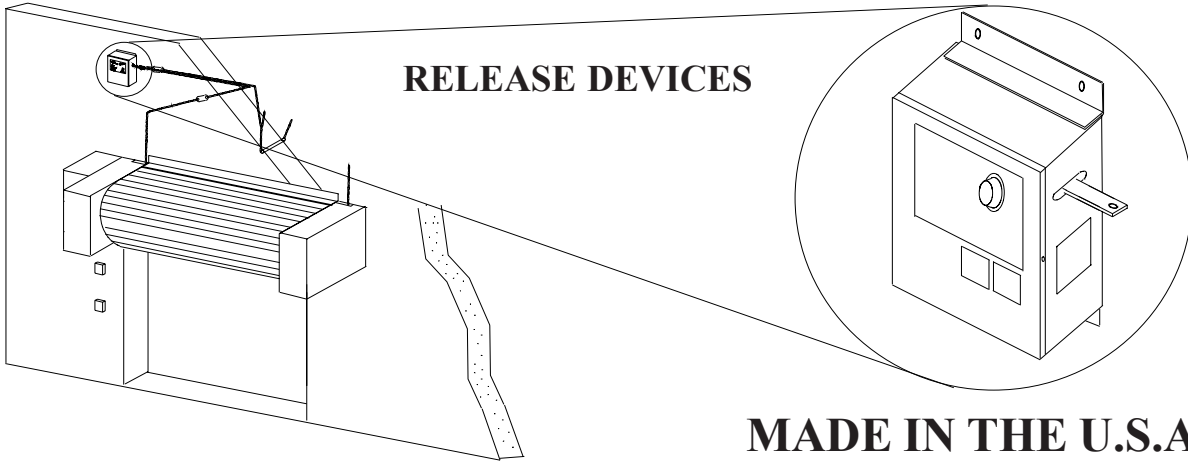

RELEASE DEVICES

MADE IN THE U.S.A.

MODEL B2 INSTALLATION MANUAL

U.L. LISTED CANADIAN LISTED CSFM: 7300-1418:100

GENERAL DESCRIPTION

S/N: _____

The B2 Series Time Delay Release Devices are UL Listed, Canadian Listed, and CSFM Listed for use on rolling doors, single-slide and center parting level and inclined track doors. All models are normally energized Fail-Safe Releasing Devices incorporating an internal 72 hour battery pack and state of the art electronic control circuitry. The Release Devices respond to emergency conditions generated by manual or automatic normally closed initiating devices and shall be used in conjunction with a temperature fuse link system.

The Release Device features include separate adjustable time delays for alarm and power loss, up to 72 hours battery support for release and smoke detectors, motor voltage sensing, form-C relay outputs, proximity/down limit detection, annunciator outputs with voice module options and trouble diagnostic capabilities.

CAUTION: Review all installation instructions, procedures, cautions and warnings contained within this manual prior to installing and/or servicing this product. As with all releasing device systems, maximum fire protection is provided when installed in accordance with factory specifications and used with fuse link systems.

Fail-safe operation can only be provided with input power applied. DO NOT install this unit without fuse links.

TEST SYSTEM WEEKLY TO ASSURE PROPER OPERATION.

Installation and testing to factory specifications shall be performed by factory authorized personnel for proper operation in accordance with all of the latest National Fire Protection Association (NFPA), Underwriters Laboratories (UL), National Electrical Code (NEC), local, state, county, district and/or other applicable building and fire standards, guidelines, regulations and codes including, but not limited to, all appendices and amendments and the requirements of the local authority having jurisdiction (AHJ).

LISTED



99Y9

RELEASING DEVICE



LISTED



99Y9

RELEASING DEVICE
SYSTÈME DE DÉBRAYAGE

INSTALLATION INSTRUCTIONS -To be performed by factory authorized personnel only.

The following installation procedures must be followed to assure performance of the release device/control panel to factory standards.

A. MOUNTING PROCEDURE

(Figure 1) - Typical installation configuration may not accurately depict door manufacturer's recommendations. See door manufacturer's recommendations for use of this product with specific door being installed. All hardware required shall be supplied by the door installer or manufacturer. Use only hardware approved or recognized by the appropriate testing or listing agencies in conjunction with the installation of this product.

1. The release device shall be mounted on a vertical surface with chain end link exiting side of enclosure as illustrated in figure 1.
2. Release device enclosure shall be mounted with minimum #10 size fastening screws or bolts for securing to structures other than masonry. Masonry applications shall utilize 1/4" or greater anchors or studs as required to insure proper mounting strength.

*** TYPICAL INSTALLATION**

FIGURE 1

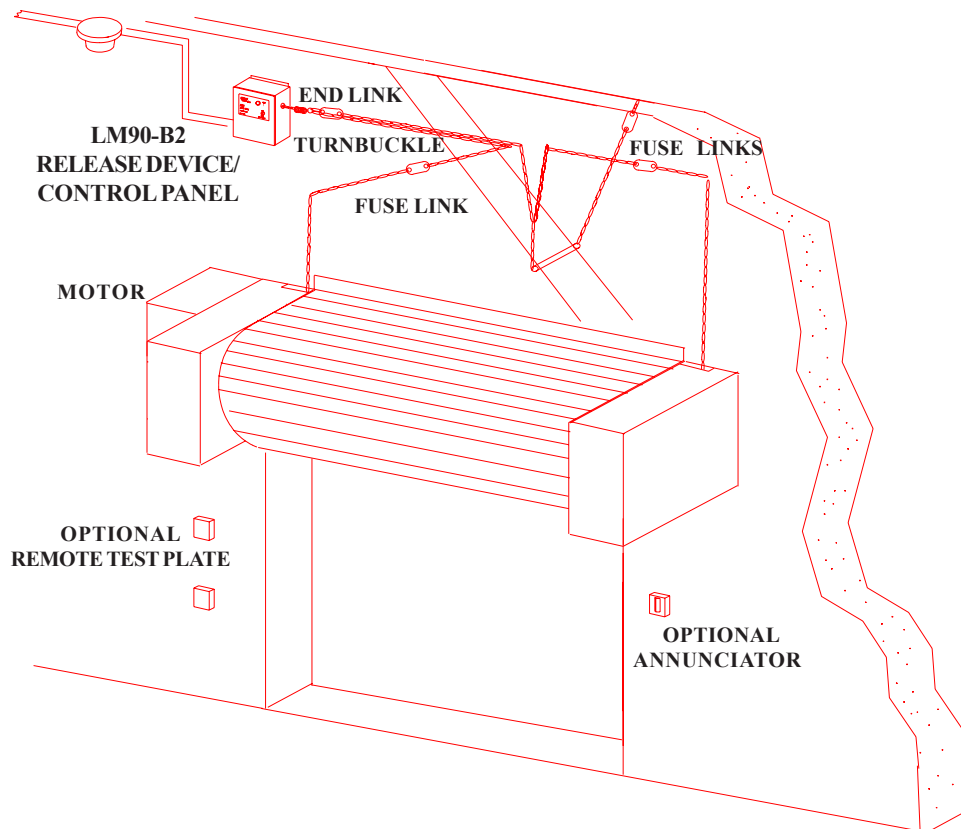

* Actual configuration may differ. See door manufacturers recommendations for use of this device with specific door.

3. Release device and associated hardware (sash chain or 1/16 cable, eyebolts, ***fuse links**, turnbuckles) shall be installed as per Figure 1 or door manufacturers recommendations. Take note that the end link direction of pull is perpendicular to the enclosure side. An eyebolt installed at a minimum distance of 12 inches from the release device will adequately redirect sash chain pull illustrated in figure 1. ***DO NOT install this unit without fuse links!**
4. Complete hardware installation by connecting fuse links, sash chain, S- hooks and turnbuckles where required. Push reset lever in direction of arrow on label to allow insertion of end link through release device side opening. Push end link completely in and release reset lever to latch end link. Remove sash chain slack by adjusting turnbuckle. **Do Not exceed 40 Lb. max. pull rating on device.**

MODEL LM90-B2 INSIDE VIEW

FIGURE 1A

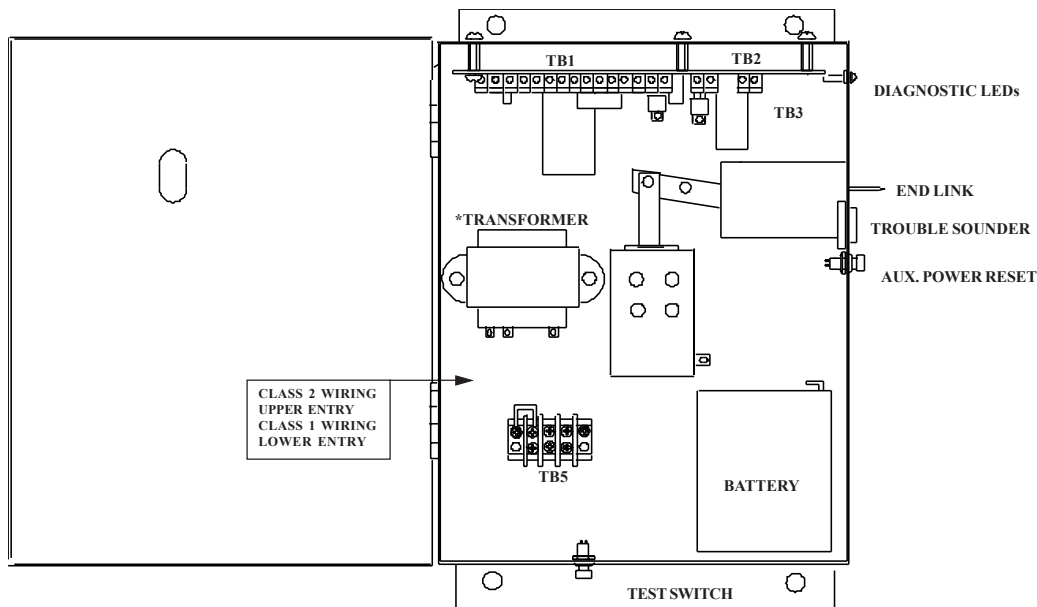

* TRANSFORMER FOUND IN 120VAC MODELS ONLY

B. SMOKE DETECTORS.

When installing smoke detectors with this unit refer to NFPA 72 and NFPA 80, for instructions concerning proper placement and detection coverage. See Electrical Connections page 6 for wiring information. End of line devices shall be installed for supervision of electrical power to smoke detectors. “DO NOT” interface this unit to smoke detectors if electrical supervision is not provided!

C. ELECTRICAL CONNECTIONS

Installation of all wiring and connections, including Class 1 and Class 2 circuits, shall be performed in accordance with, but not limited to, the latest NFPA, UL and NEC standards and codes. In addition, all installations subject to Canadian standards shall be performed in accordance with the Canadian Electrical Code, Part I, with respect to wiring material type, wiring gauge related to power capacity requirements and circuit length and wiring methods. This unit is designed so that it may be used on automated motorized doors which incorporate appropriate safety features. See options below.

Electrical Connections Continued

See Figure 2

1. Turn off power supply sources for Model B2 as well as motor where applicable before beginning.
2. Verify voltage rating of release device/control panel to power source being utilized. Model voltage is indicated on side of unit.
3. Connect power source inputs to TB5 (chassis mount), screws 1 & 2. On 24VDC units observe proper polarity by placing positive (+) wire to screw 1. TB5 screw 3 shall be utilized for earth ground where applicable. "DO NOT" connect battery at this time!
- * 4.(a) **Normally closed initiating devices** - remove jumper from TB1 screws 2 & 3. Connect wiring from N/C initiating device loop to TB1 screws 2 & 3. Auxiliary power (+12VDC) for smoke detectors may be obtained from TB2 which provides it's power from an internal battery pack. Observe proper polarity, TB2-2 (+), TB2-1 (-). 4 detector maximum.
(b) **Normally open initiating devices** - Both the N/C and N/O alarm inputs may be used simultaneously, but if the N/C loop is "Not" used, make sure jumper is installed across TB1 screws 2 & 3. Connect wiring from N/O initiating device loop to TB1 screws 4 & 5, making sure end of line supervisory resistor (51 Kohm @ 1/4 Watt) is installed as indicated. Auxiliary power (+12VDC) for smoke detectors may be obtained from TB2. Observe proper polarity, TB2-2 (+), TB2-1 (-). 4 detector maximum. Electrical power supervision in the form of an End of Line Device shall be provided on all smoke detectors.

*** Note: TB1 initiating device loops are supervised and cannot be directly series or paralleled between multiple release devices or shared with other alarm equipment. For proper wiring configurations from multiple smoke detectors or signalling for simultaneous closure on multiple doors call tech support. Incorrect wiring from unit to unit may cause damage to release and void warranty.**

OPTIONS:

Motor voltage sensing

This option is used to detect the presence of operating voltage on motor driven units where closings are automated by a fire alarm signaling source in conjunction with the operator. When motor control secondary voltage is present (24V-30V AC or dc) the release device logic will prevent the solenoid from energizing on alarm, thereby allowing the motor to drive the door closed by activation from the automated fire alarm signaling source through the operator.

CAUTION: The automated signaling source and/or the motor operator shall contain logic capable of determining whether the door has fully closed upon activation. In absence of full closure, the motor control voltage shall be interrupted to release device allowing for release device initiated closure.
CAUTION: "DO NOT" use this option on non-automated installations where door closings through the motor can only be initiated manually .

***DOOR EDGE (Down limit detection)**

This option interfaces to electrical contact type lower limit sensing devices and/or magnetic proximity type switches and must be used when the "motor voltage" option is used. If the electrical contact has toggled states from its N/C condition (switch closed when door is "NOT" at lower limit) indicating the door edge has made contact with desired down position, the release device logic will prevent the solenoid from energizing on alarm, thereby eliminating any damage which may result to the door from the release device attempting to close the already lowered door.

5. Connect motor control sensing voltage (24-30V, AC or DC) from motor controller transformer secondary to TB3 screws 1 (+) & 2 (-) Observe proper polarity with DC control voltages.

Electrical Connections continued

* **6.Lower limit switch.** Connect wiring from N/O electrical loop (switch open when door is up) to TB1 screws 1 & 16 or N/O electrical loop (switch closed with door up) to TB1-1 & 18.

* **Note: Electrical loop must be provided as dry contacts and may not be used in conjunction with the simultaneous switching of a motor control or any other voltage through the same contacts. Connections of this type will result in immediate damage to the release device.**

7. Annunciator - (+12VDC output) connect annunciator (option) observing polarity to TB1-6 (-) & 7 (+).

If voice option is included see LM21-VAS, Installation manual. **Do Not** connect a speaker to this output.

8. Relay outputs - Two separate SPDT dry contact relay outputs are provided for switching of devices external to the release device. A non-delayed output (relay toggles on alarm- beginning of time delay) is provided on TB1-10,11 &12 and a delayed relay output (relay toggles after time delay) is provided on TB1-14,15 &17.

See Figure 2 for contact status and ratings.

Note: Battery should “not” be connected until testing of unit is being performed!

TESTING OF RELEASE DEVICE/CONTROL PANEL SHALL BE PERFORMED AND WITNESSED FOR NORMAL OPERATION AFTER INSTALLATION. REFER TO TEST PROCEDURES CONTAINED HEREIN, AS WELLAS ANY OTHER TESTING PROGRAMS RECOMMENDED BY DOOR MANUFACTURER.

**"LM90"SERIES MODEL B2 RELEASE DEVICE
ELECTRICAL & MECHANICAL SPECIFICATIONS**

OPERATING VOLTAGES

MODEL	
LM90-B2-24DC 24VDC +/- 5%
LM90-B2-24AC 24VAC +/- 10%
LM90-B2-120AC 120VAC +/- 10%

CURRENT REQUIREMENTS

MODEL	
LM90-B2-24DC SUPERVISORY (non-alarm) .100A / ALARM .500A MAX
LM90-B2-24AC SUPERVISORY (non-alarm) .100A / ALARM .500A MAX
LM90-B2-120AC SUPERVISORY (non-alarm) .100A / ALARM .500A MAX

* NOTE: Initial power up inrush current shall not exceed 3 times rated current on any model.

MOTOR CONTROL SENSE - ALL MODELS

Input Voltage: 24V AC/dc typical +15% / -10%
Input Current: Not to exceed .004A

INITIATING/DOOR INPUTS

CAUTION: All initiating devices shall be dry contact type only
Maximum loop resistance: 100 Ohms
Maximum current: Not to exceed .002A
Maximum voltage: 15VDC

FORM C OUTPUT (MAXIMUM CONTACT RATING)

2A/30VDC 60 Watt DC Resistive Load Only

AUXILIARY POWER: 12VDC @ .250A **FUSES** All fuses 1A @250V, 2AG Fast Acting Type

MECHANICAL SPECIFICATIONS

LOAD RATING

Support and Release : 40 LB. MAXIMUM

PHYSICAL DIMENSIONS

9.125" x 9.125" x 4.750" (H x W x D)

LM90-B2 ELECTRICAL CONNECTIONS

NOTE: WHEN INSTALLING LM90-B2 MASTER AND REMOTE DEVICES, REFER TO FIGURE 3A ON PAGE 8, FOR WIRING INSTRUCTIONS.

FIGURE 2

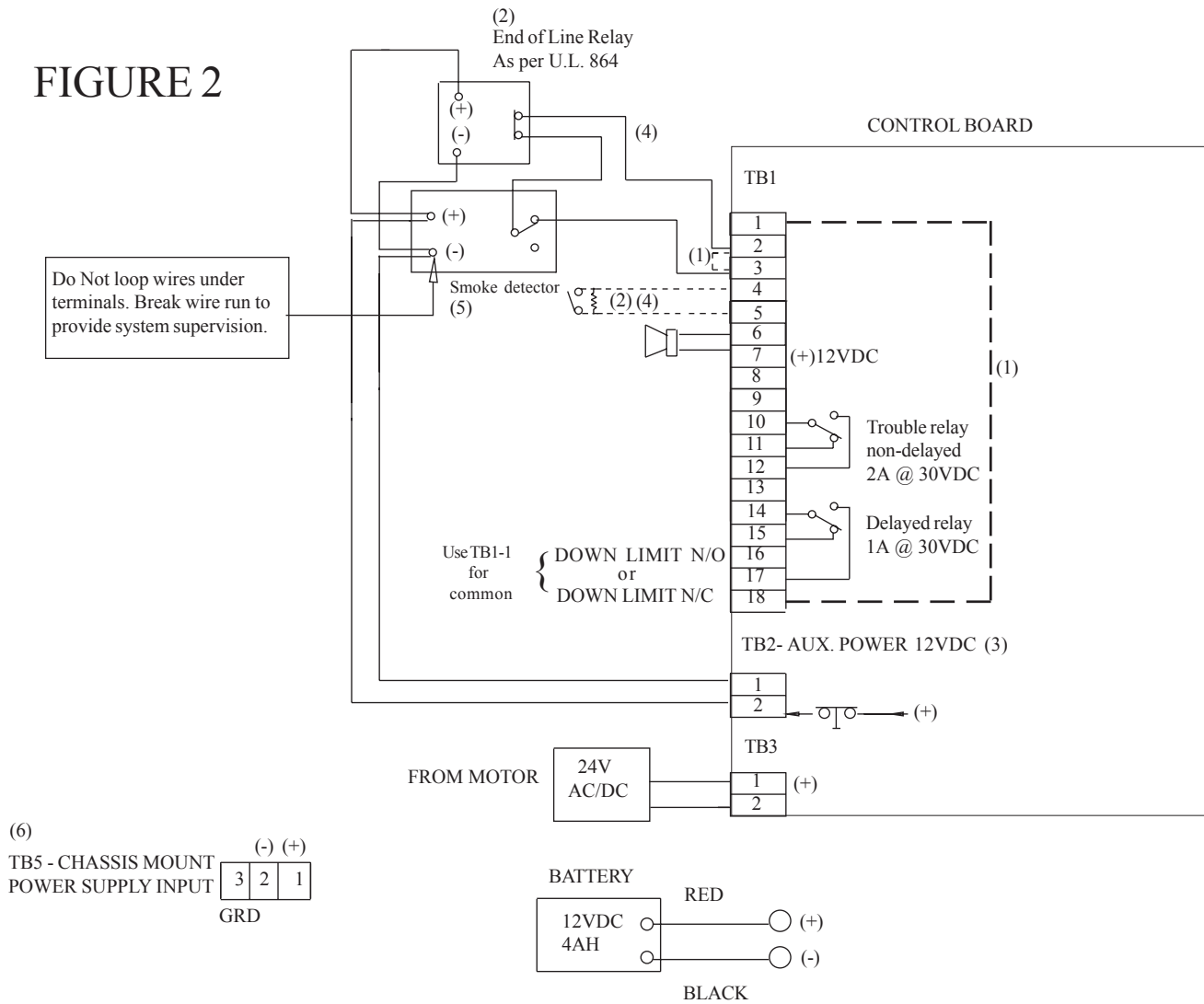

- (1) FACTORY INSTALLED JUMPERS: REMOVE WHEN CONNECTING TO N/C DEVICE. DOWN LIMIT DETECTION SHOULD NOT BE USED WHEN POWERING REMOTE RELEASES FROM THIS UNIT. CALL TECH SUPPORT FOR COMPLETE DETAILS.
- (2) SUPERVISORY DEVICE MUST BE INSTALLED
- (3) AUX. POWER IS 12VDC ON ALL MODELS. ALL FUSES 1A @ 250V, 2AG FAST ACTING
- (4) MAXIMUM LOOP RESISTANCE 100 OHMS
- (5) SEE NFPA 80 AND NFPA 72 FOR PROPER PLACEMENT OF DETECTOR
- (6) CLASS 1 WIRING MUST ENTER PROPER OPENING. SEE FIGURE 1A

Installation of all wiring must be performed in accordance with, but not limited to, the latest NFPA, U.L. and NEC standards and codes, as well as the requirements of the final authority having jurisdiction. In addition, all installations subject to the Canadian standards, shall be performed in accordance with the Canadian Electrical Code, Part I, with respect to wiring type, wiring gauge related to power capacity requirements and circuit length and wiring methods.

SECTION D. TEST PROCEDURES

TO BE PERFORMED BY FACTORY AUTHORIZED PERSONNEL ONLY! CLEAR FIRE DOOR OPENING AND PROHIBIT TRAFFIC THROUGH DOOR OPENING WHILE TESTING!

Testing does not affect normal operation of alarm system when connected to release device/control panel. Complete testing can only be accomplished with power applied to unit. This procedure describes testing of all features standard to this unit. Verify options being used, as well as factory ordered options. All tests may not apply.

A) POWER UP SEQUENCE:

Turn on power to unit. When power is applied to unit under test the Power LED (red) will light on the bottom of the release device and the battery trouble sounder will begin to beep. Connect battery leads to silence battery trouble. Green LED will light indicating battery is connected and charging.

Make sure power is “off” to motor at this time (if unit is installed on motorized door) and door is in open position.

Test Procedure:

1. Enclosure mounted test switch: Depress and continue to hold test button on side of release device/control panel. Annunciator (option) will turn on indicating a door closure is about to occur and after 10 second alarm delay unit will release door. Release test button.
2. Leave door in closed position. Note the amber Motor Sense/"Lower Limit" LED is lit indicating that the door is in the closed position (applicable when lower limit feature is used). Depress and continue to hold test button on side of release device/control panel. Active “Lower Limit” logic will inhibit the unit from releasing the door.
3. Reset fire door and then reset release device by pushing reset lever in direction of arrow as indicated on device label. Fully insert end link trough release device side opening and release lever to latch end link. Raise door.

Note: with door open the amber LED is now off.

FOR DESCRIPTION OF "MOTOR SENSE" FEATURE REFER TO SECTION C - ELECTRICAL CONNECTIONS.

Turn on power to motor when applicable. “Motor Sense”/Lower Limit (amber) LED will turn on once again indicating power is present at motor control secondary.

4. Depress and continue to hold test button on side of release device/control panel. Annunciator (option) will turn on indicating a door closure is about to occur. Active Motor Sense logic will stop the release device from energizing. Release test button.
5. After completing all tests, verify that door is in normal condition (open or closed) and that all power required for normal operation is restored to unit and operator if applicable. This equipment is designed to operate using its primary power source.

B) POWER LOSS TEST:

Power Loss test is not required. This unit contains diagnostic logic, which when operating under conditions of extended power loss, will initiate a door release. The unit contains a trouble sounder (chassis mounted) which will sound indicating that a low battery condition exists, once the battery backup drops below a predetermined battery level. If the optional external sounder is being used, it will also begin to sound 10 seconds prior to door closure.

REMINDER: TESTING OF RELEASE DEVICE/CONTROL PANEL SHALL BE PERFORMED AND WITNESSED FOR NORMAL OPERATION AFTER INSTALLATION. TEST WEEKLY TO ASSURE PROPER OPERATION OF RELEASE DEVICE/CONTROL PANEL!

Testing of the LM90-B2 release device/control panel is independent of, and shall in no way be interpreted as an alternative method of, testing of the fire alarm system, motorized operator and/or any other system component employed on the fire door or counter fire door installation.

FIGURE 3A - ELECTRICAL WIRING : CONNECTIONS TO LM90 REMOTE RELEASE

NOTE: THIS SECTION ONLY APPLIES WHEN INSTALLING LM90-B2 MASTER WITH REMOTE RELEASE DEVICES

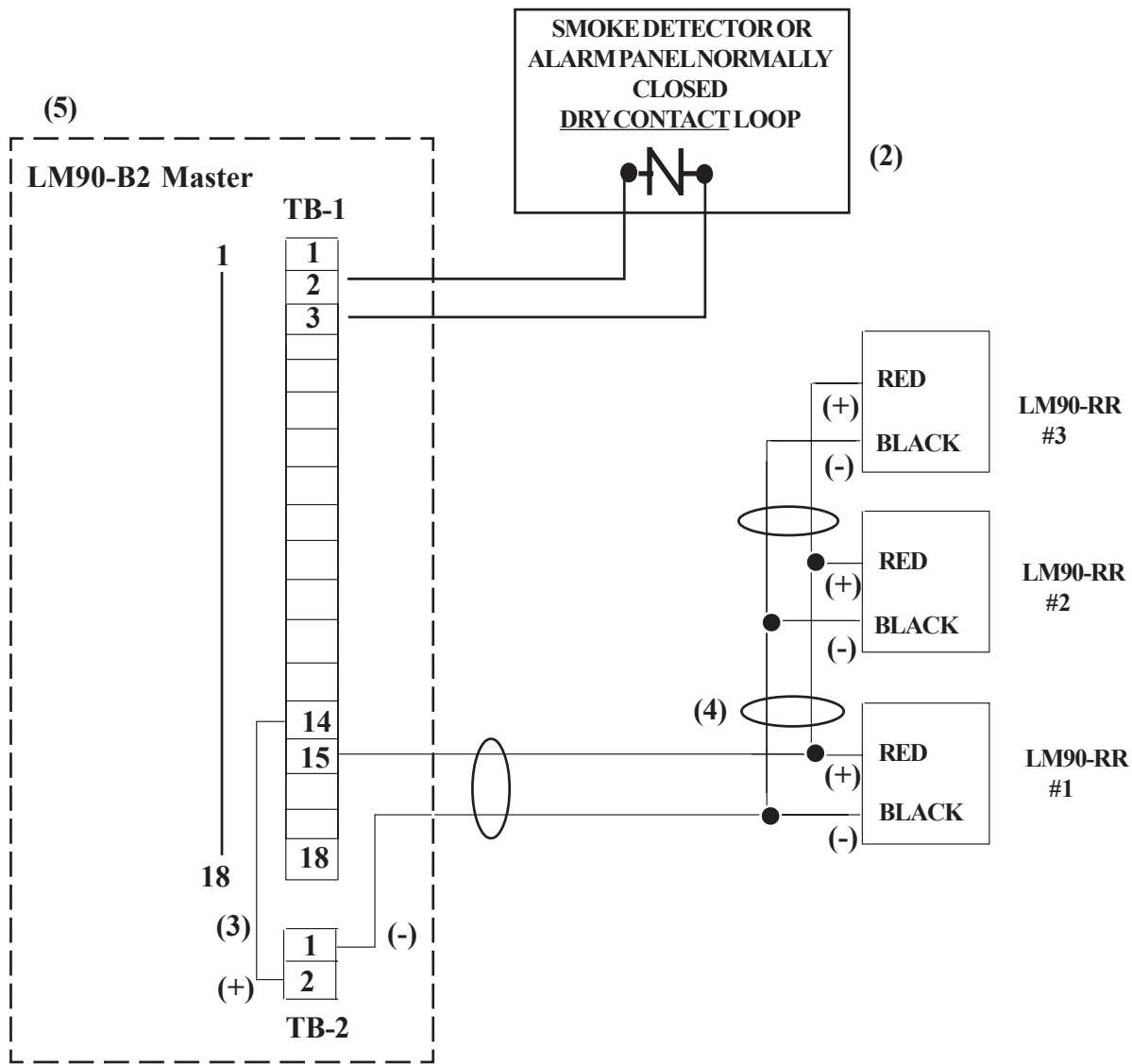

Refer to page 3, Section C for wiring descriptions.

Wiring of the remote releases in a daisy chain configuration to a master unit (LM90-B2 Master) provides time delayed release with simultaneous closure on all doors. A maximum of three (3) units may be daisy chained from the master unit.

- (1) Verify model being used as LM90-RR-12. Do not use LM90-RR-24.
- (2) See NFPA 80 and NFPA 72 for proper placement. Electrical supervision of detector shall be provided as per UL 864
- (3) Install jumper between TB2-2 and TB1-14 of master unit.
- (4) Wiring between units is parallel connected. DO NOT series connect units.
- (5) Illustration does not depict entire master unit. See installation manual of master unit for additional information.

Installation of all wiring and related connecting hardware must be performed in accordance with the latest NFPA, UL., and NEC standards and codes. In addition, all installations subject to Canadian standards shall be performed in accordance with the Canadian Electrical Code, Part I, with respect to wiring material type, wiring gauge related to power capacity requirements and circuit length and wiring methods.

MAINTENANCE REQUIREMENTS

The LM90-B2 release devices have been designed to require a minimum amount of system maintenance when installed and used in accordance with factory specifications. The unit has been designed and tested for use in indoor locations. Weekly testing of the unit is recommended, but test intervals shall ultimately be subject to criteria established by the Final Authority Having Jurisdiction (AHJ).

Serviceable fuses are provided for the following:
See Figure 5 for fuse locations.

Fuses:

- F1 1A @ 250V, 2AG Fast Acting, Input Power
- F2 1A @ 250V, 2AG Fast Acting, Logic/Aux. Power
- F3 1A @ 250V, 2AG Fast Acting, Battery
- F4 1A @ 250V, 2AG Fast Acting, Motor Sense

Replacement fuses shall be of equivalent rating and type may be ordered directly from the factory through the technical support number provided on the last page.

Should servicing of fuses be required, personnel authorized to perform such maintenance shall ensure that;
a) all traffic is prohibited through door opening, b) door is mechanically released and fully closed, c) all power is disconnected from unit, including motor sense voltage on motorized doors.

After servicing equipment as required, unit shall be tested and witnessed for proper operation as described in the **TEST PROCEDURES**, contained herein

FIGURE 3

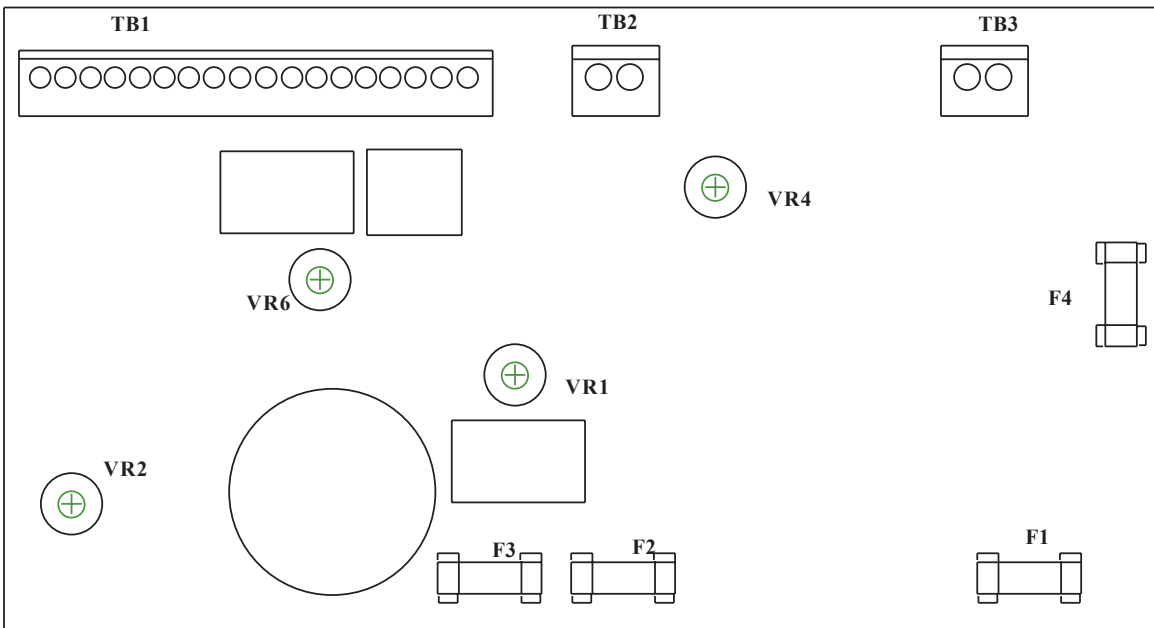

ADDENDUM

MODEL LM90-B2 TROUBLESHOOTING GUIDE

Verify that desired options are available on unit before troubleshooting. Refer to pages 2 & 2A for electrical connection information and the maintenance and service page of this manual for fuse locations. Troubleshooting shall be performed by factory authorized personnel only. Service and/or installation by unauthorized personnel shall void warranty. Review the following guide prior to requesting technical support. If technical support is required, unit serial number (found on front of manual and inside unit), as well as distributor who supplied unit must be supplied.

SYMPTOM

POSSIBLE TROUBLE

1. Red Power LED does not light.
 - A) Primary power source turned off.
 - B) Loose connection on TB5
 - C) Incorrect polarity on D.C. unit
 - D) Incorrect power source applied. Verify voltage and check fuse F1.

2. Green Battery LED does not light & trouble sounder stays on.
 - A) Battery leads not connected or leads may have bad connector.
 - B) Battery connected with using incorrect polarity. Red (+) Black (-). Check fuse F3
 - C) Battery threshold circuit requires adjustment. Call Tech Support!
 - D) Battery totally discharged. Replace battery.

3. Amber Disable LED does not light
 - A) Motor control voltage not connected to TB3
 - B) Motor control is D.C.. Check polarity.
 - C) Control voltage is above 30V. Check fuse F4.

4. Unit goes into alarm as soon as power is applied
 - A) Alarm loop is not connected properly to TB1.
 - B) Alarm loop which is not being used must have jumper or resistor installed. If using N/C loop (TB1-2&3), resistor must remain in TB1-4&5, etc.

5. Annunciator does not shut off when door meets down limit.
 - A) Aux. down limit switch not connected properly.
 - B) If using N/O down limit TB1-1&16, jumper must remain in TB1-1&18.

6. Unit closes door before optional voice message is complete.
 - A) Alarm delay must be lengthened to accommodate message. Call Tech Support!

7. Unit does not respond to manual test button.
 - A) Unit is detecting down limit. Make sure Aux. down limit is connected properly. If N/O down limit is used, N/C loop (TB1-1&18) must have jumper installed.
 - B) Possible defective switch. Call tech support.

Warranty Service Procedure

Contact technical support at the number provided below for assistance in determining possible product failure. Installer shall provide the following information when contacting technical support:

- 1) Unit Serial Number, found in the following locations
 - a) Individual unit shipping box
 - b) Cover of installation manual
 - c) On unit
- 2) Name of Distributor who supplied product
- 3) Name of End User and/or installation company if different from Distributor
- 4) Detailed description of product non conformity

To receive a Return Goods Authorization (RGA) and shipping address for a Product believed to be defective, all of the above information shall be required. Products returned without a valid RGA shall be refused receipt. If provided, reference troubleshooting guide that accompanies product prior to requesting an RGA.

Contact Information

Technical Support: 1- 888-528-7870
RGA (631)467-2501, Request Customer Service